

FD-CH3

Anti-condensation heater for FD310 series

Introduction

The FD310 Series Anti-Condensation Heater has been designed to be used in environmental conditions where condensation affects the operation of optical beam smoke detectors.

Condensation occurs when the surrounding air is at a higher temperature than the surface that it comes in contact with. As air contains water, in the form of vapour, this will deposit on the cooler surface thus forming condensation.

The design of the Anti-Condensation Heater utilizes forced air, which results in a circulating current of warm air maintaining the detector lens at an incrementally higher temperature than the surrounding air. The heater will reduce the likelihood of condensation forming on the lens which, in turn, reduces the potential for false alarms.



Details

- Bespoke bracket to ensure optimum performance of heater
- Designed to prevent the build-up of condensation
- For use in temperature controlled storage areas and cold environments

FD-CH3

Anti-condensation heater for FD310 series

Technical specifications

General

Average temperature increase of lens above ambient 10°C

Electrical

Power consumption 20 W (at 24 V)

Operating voltage 24 VAC/VDC

Maximum in-rush current 3 A

Steady-state current at 24V 0.8 A (Typical)

Recommended fuse rating T2A

Connections 4 leads (2 for heater & 2 for fan)

Environmental

Operating temperature -10 to +45°C

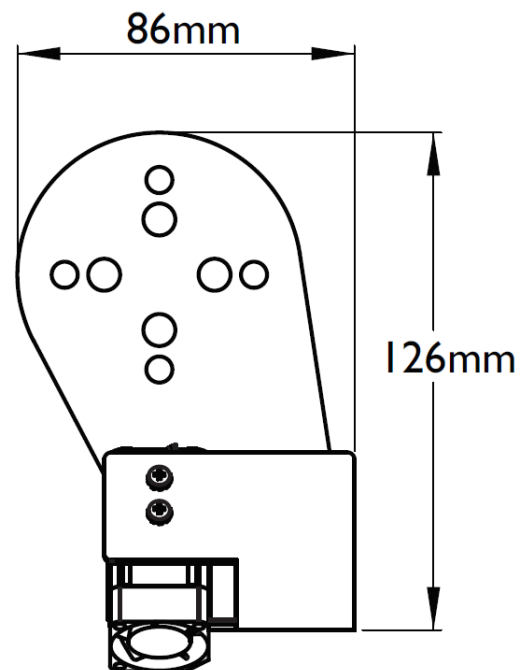

As a company of innovation, UTC Fire & Security reserves the right to change product specifications without notice. For the latest product specifications, visit UTC Fire & Security online or contact your sales representative.

Last updated on 11 February 2019 - 19:12

